



IP-Door Video Intercom
XT-11P

Quick Guide

www.xontel.com

Unpacking

Before you start using the device, please check the version you got and ensure that the following items are included in the shipped box:

Universal Accessories:

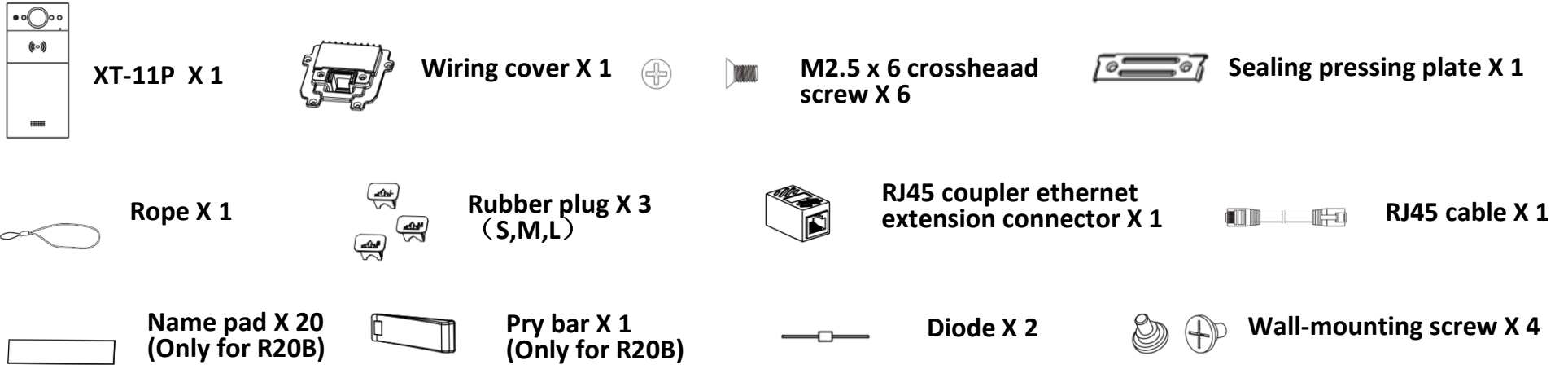

Flush-mounting Accessories:

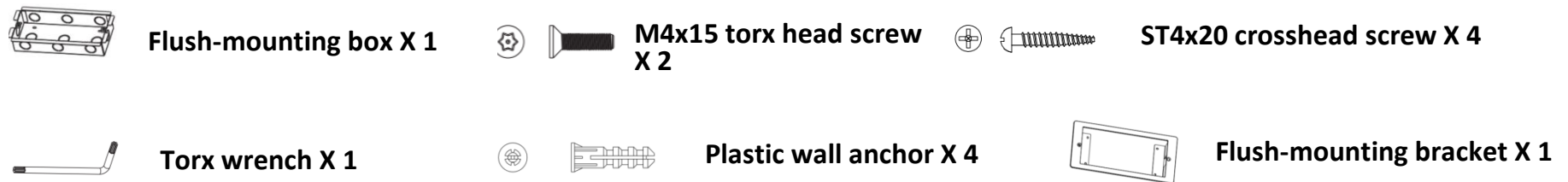

Product Overview

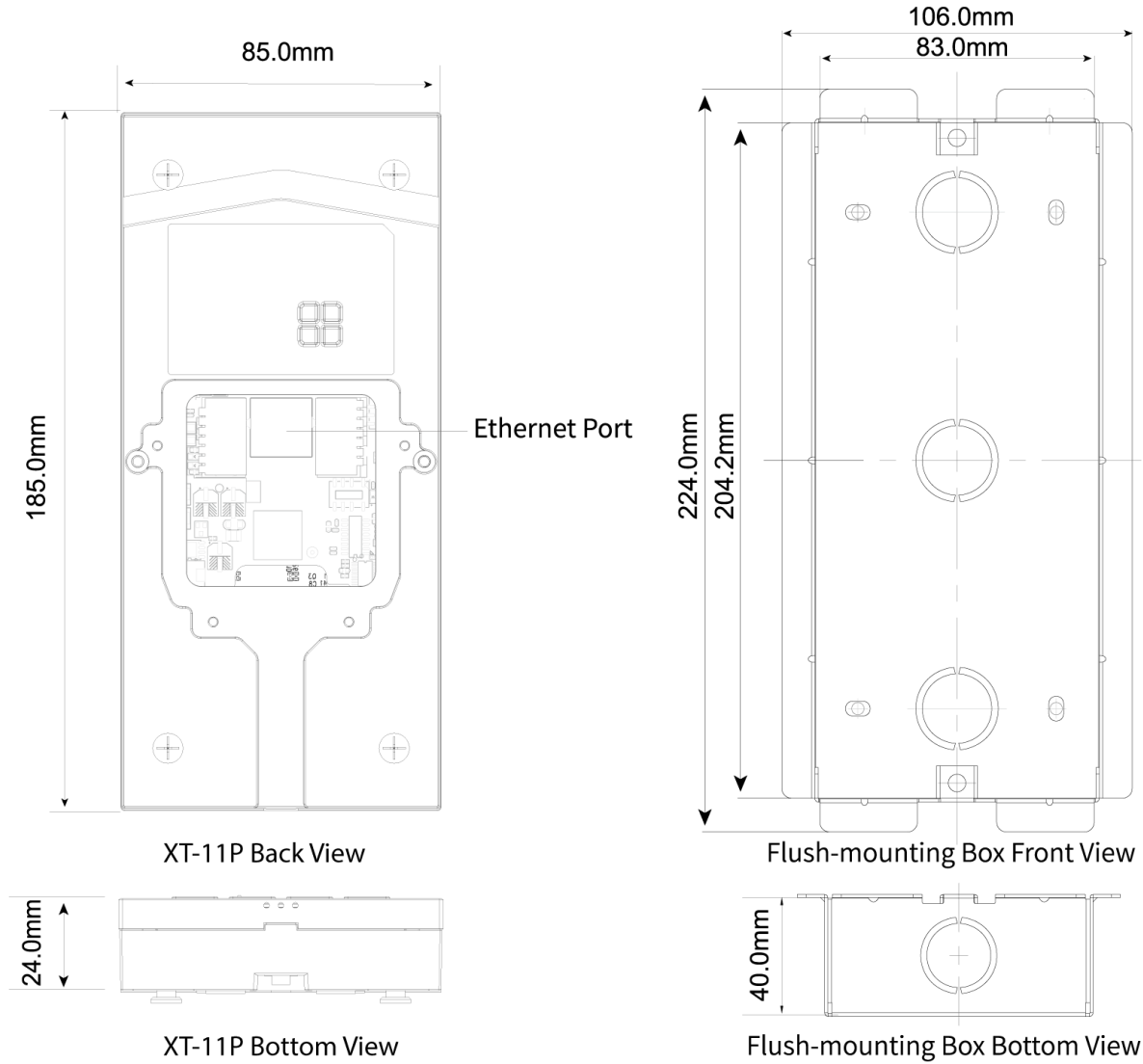

Installation Environment

Please do not place device under direct sunlight.

If installing the device indoors, please keep device at least 2 meters away from light, and at least 3 meters away from window and door.

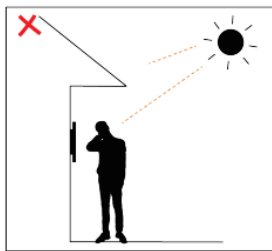

Backlight

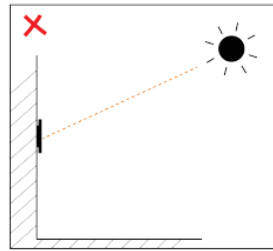

Direct sunlight

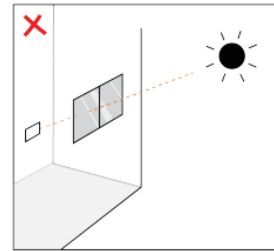

Direct sun
through window

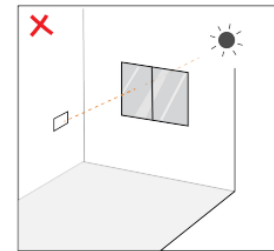

Indirect sunlight
through window

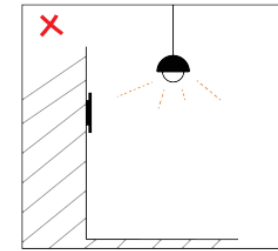

Close to light

Installation

Flush Mounting

Step1: Bracket/Box Installation

1. Normal Installation

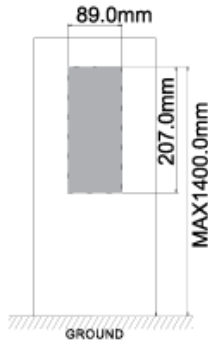

Cut a rectangular hole on the wall (height*wide*depth=207*89*40mm) that can accommodate all the cables.

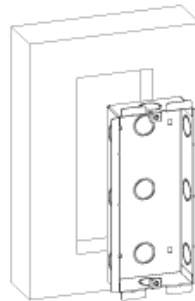

Insert the flush-mounting box into the hole.

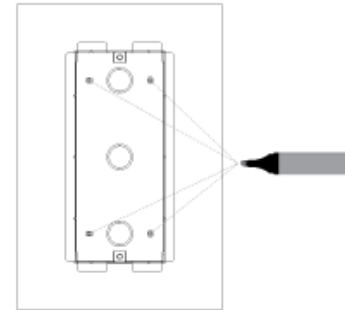

Mark the four holes of the flush-mounting box on the wall.

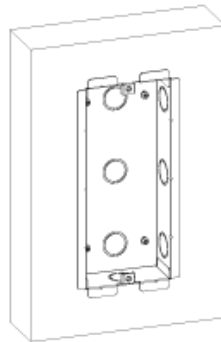

Flush-mounting box installation is completed.

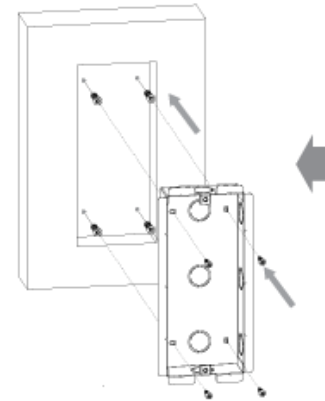

Insert four plastic wall anchors into the holes you drilled before. Fix the flush-mounting box with four ST4x20 crosshead screws.

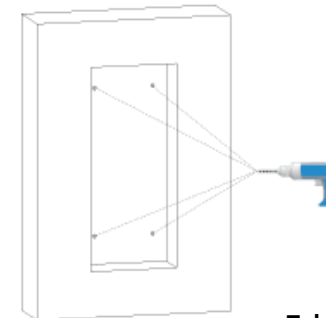

Take down the flush-mounting box, then drill (6mm drill bit required) the four marked fixing holes on the wall with a depth of 25mm.

2. Or you can choose another simple method without fixing ST4x20 crosshead screws

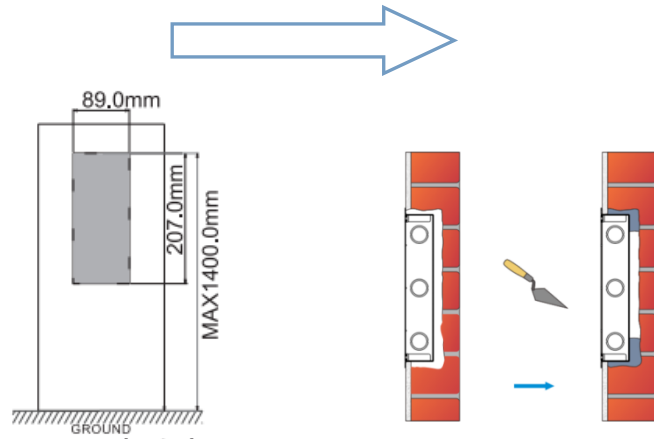

Cut a rectangular hole on the wall (height*wide*depth=207*89*40mm) that can accommodate all the cables.

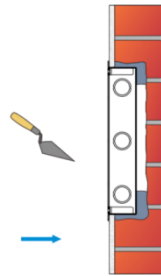

Use cement or non-corrosive structural adhesives to fill the gap between the wall and flush-mounting box. Wait for the adhesive material to dry, then go to the next step.

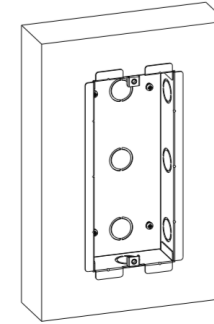

Finish the flush-mounting box installation.

Waterproof Tips:

- For flush-mounting installation, it is recommended to fill the gaps around the flush-mounting box for waterproofing (to prevent water from entering the gap in the wiring cover of the door phone).
- For wall-mounting installation, it is recommended to lock the wall-mounting bracket and the wall so that the EVA pasted on the bottom of the wall-mounting bracket is close to the wall without a gap (to prevent water from entering the gap in the wiring cover of the door phone).
- Or it is recommended to use a rain cover.

Step2: Flush-mounting Bracket Installation

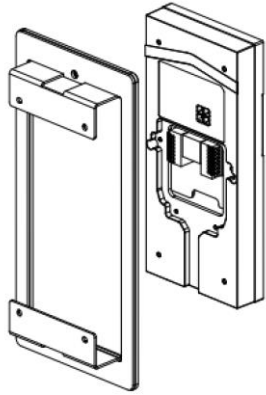

Combine the device with the flush-mounting bracket according to the direction indicated in the drawing.

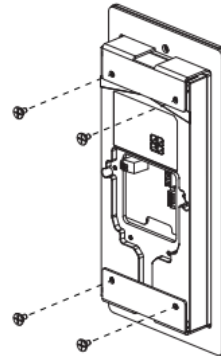

Tighten the device onto the flush-mounting bracket with four wall-mounting screws.

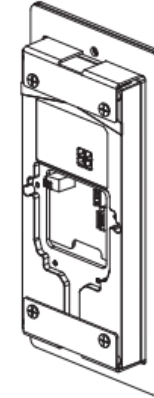

Flush-mounting bracket installation is completed.

Step2: Wiring Cover Installation

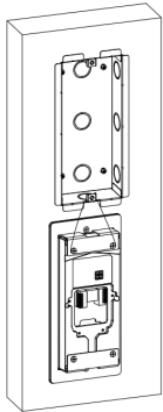

For convenient wiring, hang XT-11P on the flush-mounting box with rope.

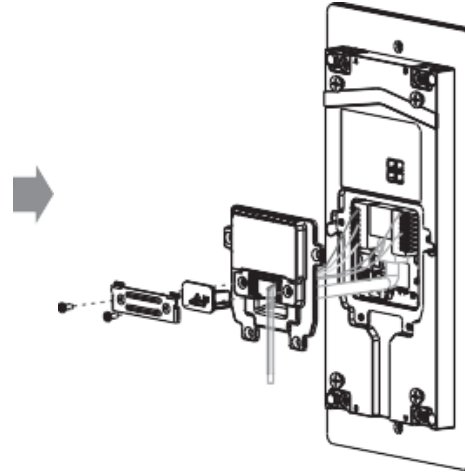

Make cables go through the wiring cover, connecting to the corresponding interfaces of the main board. Select a suitable size rubber plug to push all the cables into the wiring cover. Fix sealing pressing plate to the wiring cover with two M2.5x6 crosshead screws.

Note: In the case of one network cable or less than 6 signal cables, use S-size rubber plugs. In the case of 7 to 10 signal cables, use M-size rubber plugs. When there are more than 11 signal cables, please use L-size wiring rubber plug.

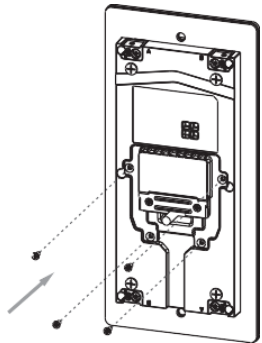

Fasten the wiring cover with four M2.5X6 screws.

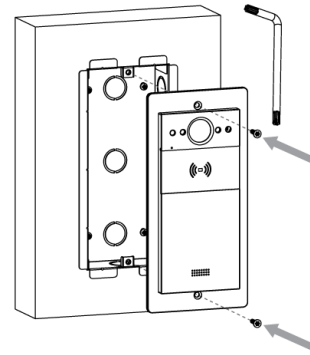

Install the device on the flush-mounting bracket using two M4x15 torx head screws.

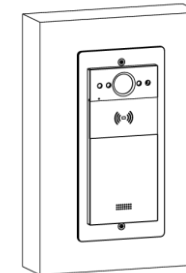

Installation completed , Please remove the protective film.

Wire Length & AWG Table

Please follow the properly measured wire gauge/length to install device:

	20 AWG	22 AWG	24 AWG	26 AWG
12V 1A Adapter	≤50m	≤40m	≤20m	\

Notice Information

XonTel XT-11P firmware contains third-party open source software under the terms of the GNU General Public License (GPL). XonTel is committed to meeting the requirements of the GNU General Public License (GPL) and will make all required source code available.

***The source code of software under the terms of GNU GPL can be downloaded online:
<http://www.xontel.com>***

Information contained in this document is believed to be accurate and reliable at the time of printing. This document is subject to change without notice, any update to this document can be viewed on XonTel's website: <http://www.xontel.com> © Copyright 2022 XonTel Ltd. All rights reserved.

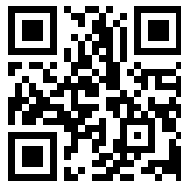

XonTel Technology CO.
www.xontel.com

www.xontel.com